

Optical Switch Series

Transmissive and Reflective Photo-interrupters

Photo-interrupters are used to detect object passage and proximity presence, and they are available in two forms: transmissive and reflective.

In the transmissive group, the infrared LED and phototransistor are contained in plastic molded package and mounted on opposing walls of a sensing gap. As object passes through the gap, the emitter light beam becomes interrupted and the sensor output shifts from a “closed” state to an “open” one.

As with the reflective group, user could provide a light detecting window with a visible light cut-off filter to reduce malfunctions caused by ambient disturbance(s).

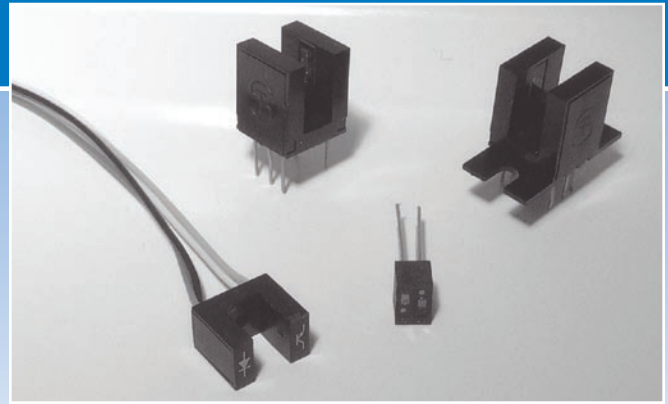

APPLICATIONS

- Disk Rotation Detection
- Paper Feed Detection
- Smoke Detector (reflective)
- Proximity Detection (reflective)

FEATURES

- Contactless Detection Capability
- Compact and Highly Reliable
- High Speed Response
- TTL Compatible
- Wire Contacts with OS-W200 Series

Model Number	LED Forward Voltage V_F (Volt)	LED Reverse Breakdown Voltage V_{BR} (Volt)		Sensor Breakdown Voltage V_B (Volt)	Sensor Light Current I_L (μ A)	Sensor Dark Current I_D (nA)		Rise Time t_r (μ s)	Temp. Range ($^{\circ}$ C)		Package Style
	$I_F=50$ mA	$BV_R@IR=10\mu$ A		$I_C=100\mu$ A	$I_F=50$ mA@ 0.4inch	$I_F=0$ mA $V_{CE}=5$ V	$V_{CC}=5$ V 1K Ω	Operating	Storage		
	typ.	min.	typ.	typ.	typ.	max.	typ.				

Reflective Transducer

OS-P085	1.3	3.0	5.0	>50	100	10	100	150	-40 ~ +100		65/Plastic Molded
Model Number	LED Forward Voltage V_F (Volt)	Sensor Saturation Voltage V_{sat} (Volt) $I_F=50$ mA		Sensor Breakdown Voltage V_B (Volt)	Sensor Light Current I_L (mA)	Sensor Dark Current I_D (nA)		Rise Time t_r (μ s)	Temp. Range ($^{\circ}$ C)		Package Style
	$I_F=50$ mA	$I_L=1.5$ mA		$I_C=100\mu$ A	$I_F=50$ mA $V_{CE}=5$ V	$I_F=0$ mA $V_{CE}=5$ V	$V_{CC}=5$ V	Operating	Storage		
	typ.	typ.		typ.	typ.	typ.	typ.				

Optical Interrupter

OS-P190	1.5	0.85	>50	3	1.3	3(rise) 10(fall)		-40 ~ +85		67/Plastic Molded
Model Number	LED Forward Voltage V_F (Volt)	Sensor Saturation Voltage V_{sat} (Volt) $I_F=35$ mA	Sensor Breakdown Voltage V_B (Volt)	Sensor Light Current I_L (mA)	Sensor Dark Current I_D (nA)		Rise Time t_r (μ s)	Temp. Range ($^{\circ}$ C)		Package Style
	$I_F=20$ mA	$V_{CC}=5$ V $R_L=10$ k Ω	$I_C=1$ mA	$I_F=35$ mA $V_{CE}=5$ V $R_L=1$ k Ω	$I_F=0$ mA $V_{CE}=5$ V			Operating	Storage	
	typ.	typ.	typ.	typ.	typ.	typ.				

'200' Series, Optical Interrupter

OS-W200A	1.2	0.12	>30	3.2	0.25	7.5(rise) 10(fall)		-40 ~ +85	66/Plastic Molded
OS-W200B	1.25	0.15		2.3	0.15	10.5 (rise) 13 (fall)			
OS-P200	1.35	0.18		2.5	0.16	12.5 (rise) 14 (fall)			

- “OS” prefix stands for Optical Switch
- “P” or “W” denotes either Pin or Wire contacts.
- Number signifies the sensing gap distance as shown in the package schematics.
- Suffix (A, B..) differentiates electro-optical disparities.
- ¶ For mechanical drawings please refer to pages 58 thru 69.

1. Parameter Definitions:

A = Distance from top of chip to top of glass.

a = Photodiode Anode.

B = Distance from top of glass to bottom of case.

c = Photodiode Cathode

(Note: cathode is common to case in metal package products unless otherwise noted).

W = Window Diameter.

F.O.V. = Field of View (see definition below).

2. Dimensions are in inches (1 inch = 25.4 mm).

3. Pin diameters are 0.018 ± 0.002" unless otherwise specified.

4. Tolerances (unless otherwise noted)

General: 0.XX ±0.01"

0.XXX ±0.005"

Chip Centering: ±0.010"

Dimension 'A': ±0.015"

5. Windows

All '**UV**' Enhanced products are provided with QUARTZ glass windows, 0.027 ± 0.002" thick.

All '**XUV**' products are provided with removable windows.

All '**DLS**' PSD products are provided with A/R coated glass windows.

All '**FIL**' photoconductive and photovoltaic products are epoxy filled instead of glass windows.

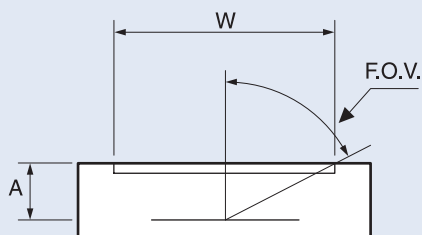

$$F.O.V. = \tan^{-1} \left(\frac{W}{2A} \right)$$



For Further Assistance
Please Call One of Our Experienced
Sales and Applications Engineers

310-978-0516



- Or -
On the Internet at

www.osioptoelectronics.com

Mechanical Specifications

All units in inches.

62 Leadless Ceramic	63 Lead Frame Moulded	64 Leadless Ceramic														
<p>Products:</p> <p>PIN-0.81-LLS PIN-4.0-LLS PIN-8.0-LLS</p> <p>Active Area</p>	<p>Products:</p> <p>DLED-660/ 880-CSL-2 DLED-660/ 895-CSL-2 DLED-660/ 905-CSL-2 DLED-660/ 905-CSL-3 DLED-660/ 940-CSL-3</p> <p>pitch = 0.05</p> <p>DLED-XXX/XXX-CSL-2 Back-to-Back Parallel Connections</p> <p>DLED-XXX/XXX-CSL-3 Common Anode Connection</p>	<p>Products:</p> <p>DLED-660/ 880-LLS-2 DLED-660/ 895-LLS-2 DLED-660/ 905-LLS-2 DLED-660/ 905-LLS-3 DLED-660/ 940-LLS-3</p> <p>Top View</p> <p>Bottom View</p> <p>DLED-XXX/XXX-LLS-2 Back-to-Back Parallel Connections</p> <p>DLED-XXX/XXX-LLS-3 Common Anode Connection</p>														
65 Plastic Moulded	66 Plastic Moulded	67 Plastic Moulded														
<p>Products:</p> <p>OS-P085</p> <p>CATHODE (-) 4 (PHOTOTRANSISTOR) (L.E.D.) ANODE (+) 3 EMITTER 2</p> <p>Bottom View</p>	<p>Products:</p> <p>OS-W200A OS-W200B</p> <p>BLACK WIRE RED WIRE WHITE WIRE YELLOW WIRE</p>	<p>Products:</p> <p>OS-P-190</p> <p>EMITTER IDENTIFICATION DOT SENSOR IDENTIFICATION DOT</p> <p>Pinout</p> <table border="1"> <thead> <tr> <th>PIN</th> <th>Description</th> </tr> </thead> <tbody> <tr> <td>1</td> <td>Emitter Cathode</td> </tr> <tr> <td>2</td> <td>Emitter Anode</td> </tr> <tr> <td>3</td> <td>Emitter Anode</td> </tr> <tr> <td>4</td> <td>Phototransistor Collector</td> </tr> <tr> <td>5</td> <td>Phototransistor Emitter</td> </tr> <tr> <td>6</td> <td>Phototransistor Emitter</td> </tr> </tbody> </table>	PIN	Description	1	Emitter Cathode	2	Emitter Anode	3	Emitter Anode	4	Phototransistor Collector	5	Phototransistor Emitter	6	Phototransistor Emitter
PIN	Description															
1	Emitter Cathode															
2	Emitter Anode															
3	Emitter Anode															
4	Phototransistor Collector															
5	Phototransistor Emitter															
6	Phototransistor Emitter															

Mechanical Specifications

All units in inches. Pinouts are bottom view.

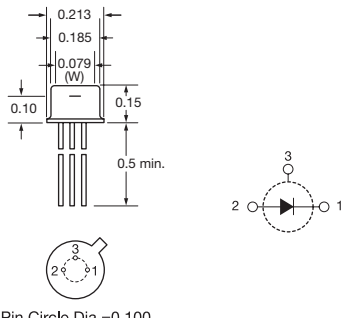
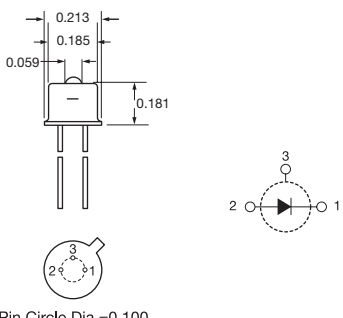
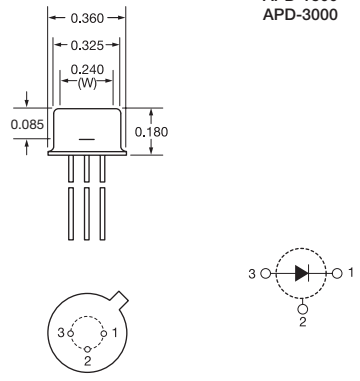
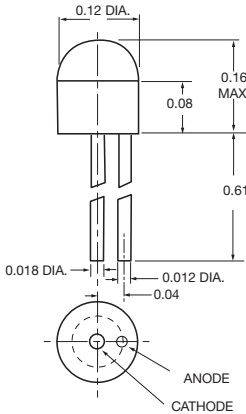
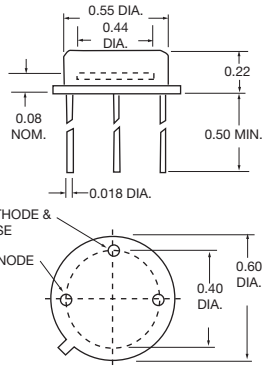
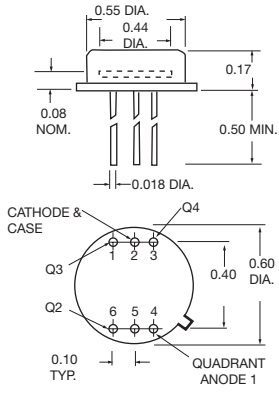
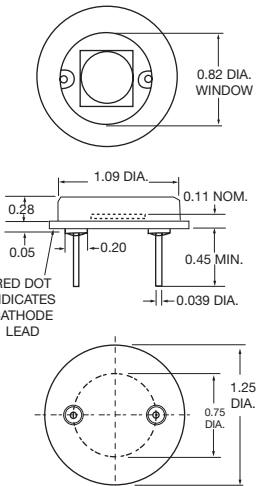
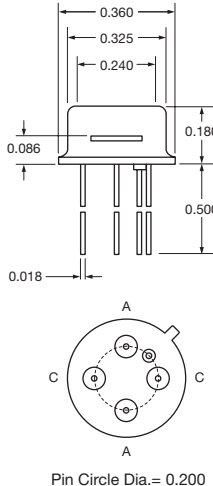
68 TO-18	69 TO-18	70 TO-5
<p>Products: APD-300 APD-500</p>  <p>Pin Circle Dia.=0.100</p>	<p>Products: APD-300L APD-500L</p>  <p>Pin Circle Dia.=0.100</p>	<p>Products: APD-900 APD-1500 APD-3000</p>  <p>Pin Circle Dia.=0.200</p>
71 Plastic	72 TO-8	73 TO-8
<p>Products: CD-1705</p>  <p>ANODE CATHODE</p>	<p>Products: OSD-60-0</p>  <p>CATHODE & CASE ANODE</p>	<p>Products: QD50-0</p>  <p>CATHODE & CASE Q4 Q3 Q2 Q1 QUADRANT ANODE 1</p>
74 Special	75 TO-5	76 Plastic Molded
<p>Products: OSD100-0A OSD100-5TA</p>  <p>RED DOT INDICATES CATHODE LEAD</p>	<p>Products: DLS-2S</p>  <p>Pin Circle Dia.= 0.200 Bottom View</p>	<p>Products: OS-P200</p> 